

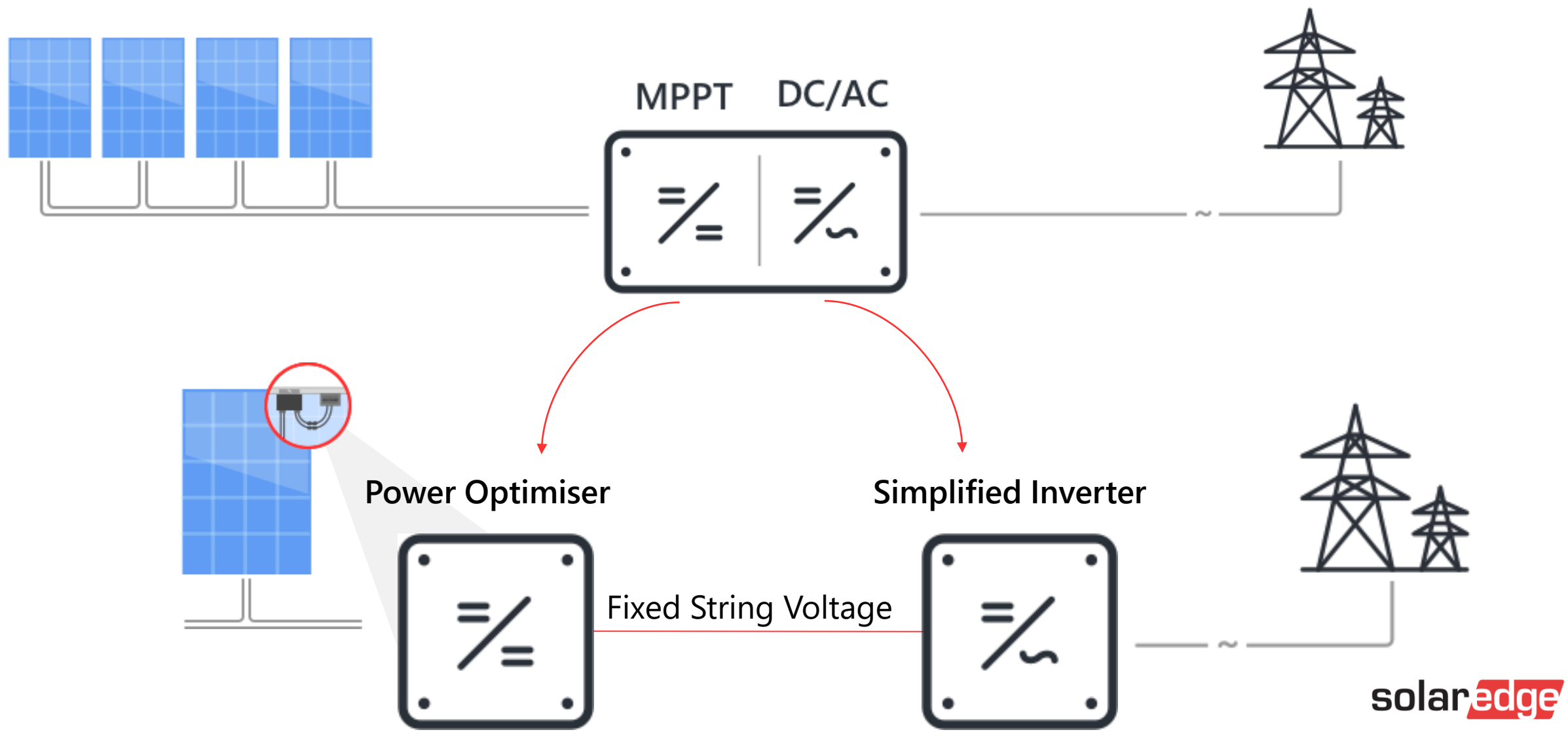

Concept Of Operation & Design Tips

Splitting Inverter Functionality



SolarEdge System – Ideal 2.8kW System

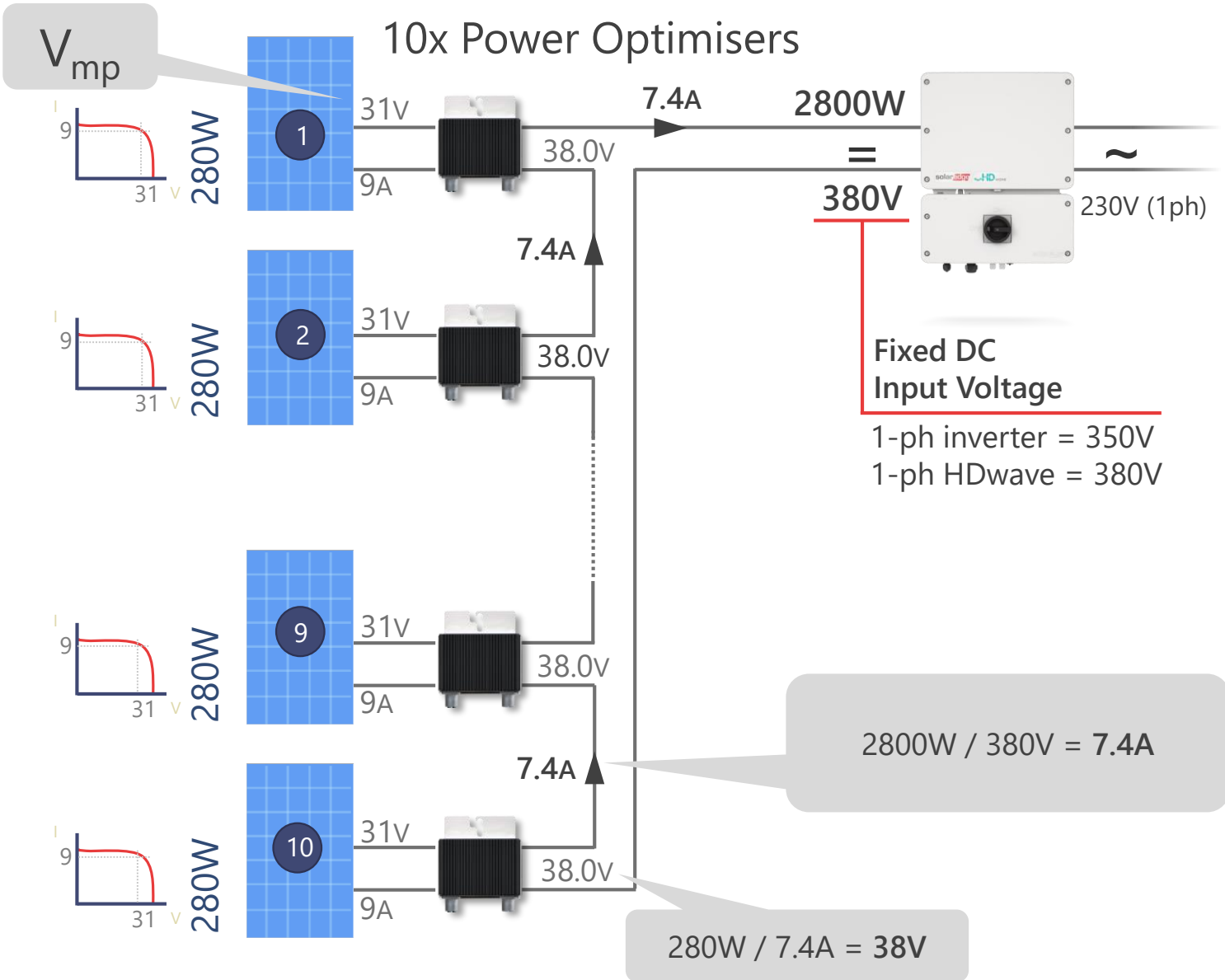

SolarEdge System – 1 Shaded Panel

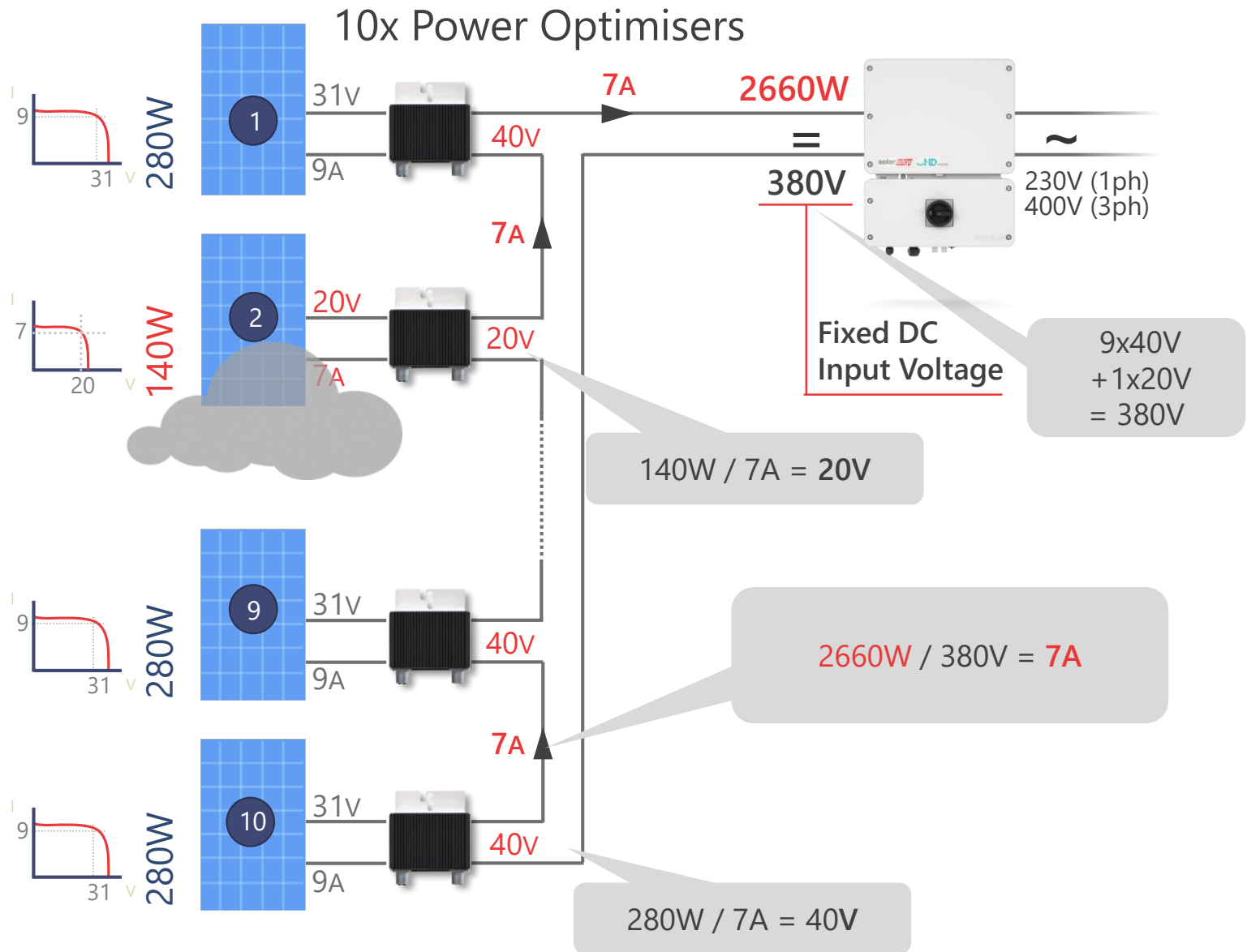

SolarEdge System – 1 Dead Panel

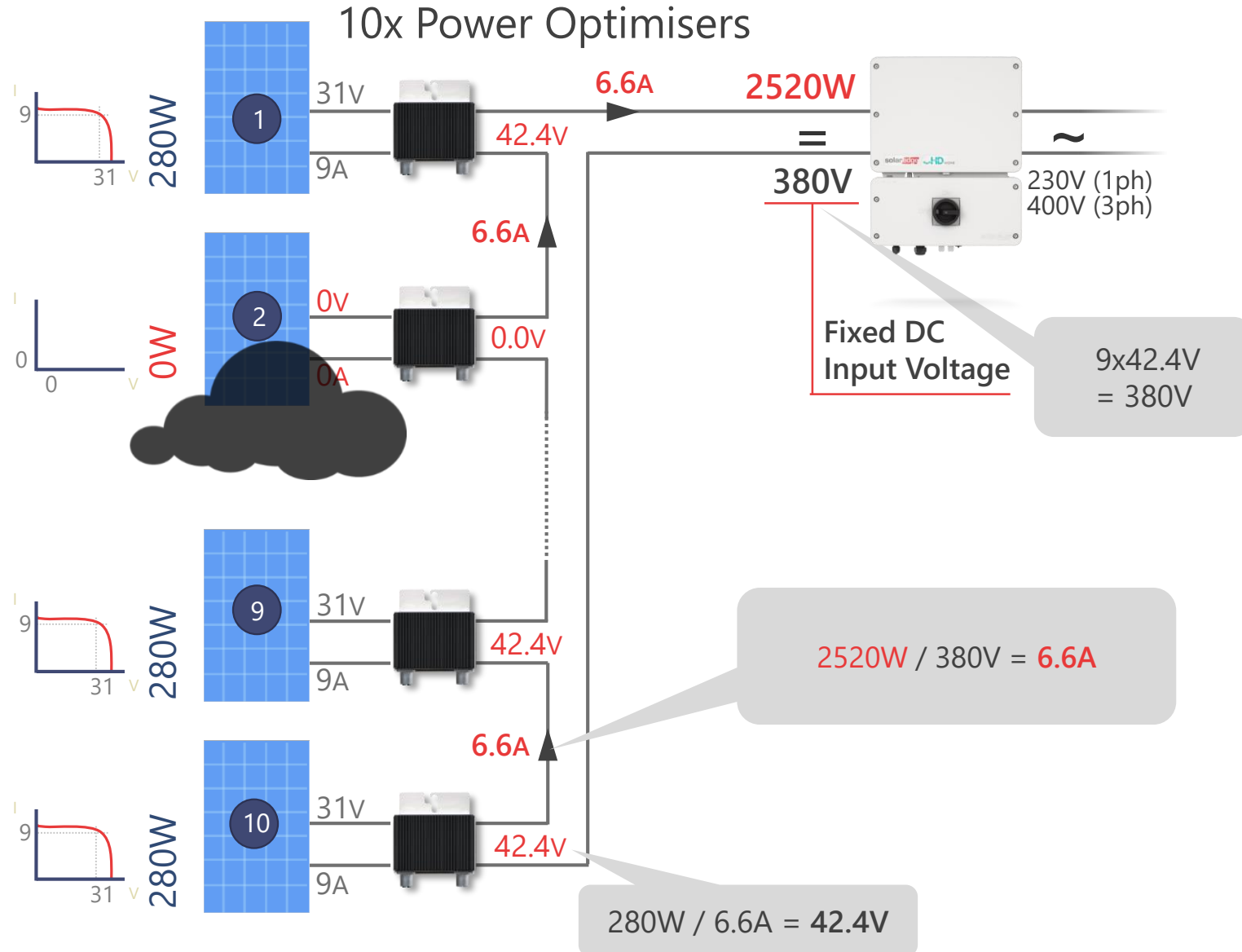

SolarEdge System – “Safe DC” Mode

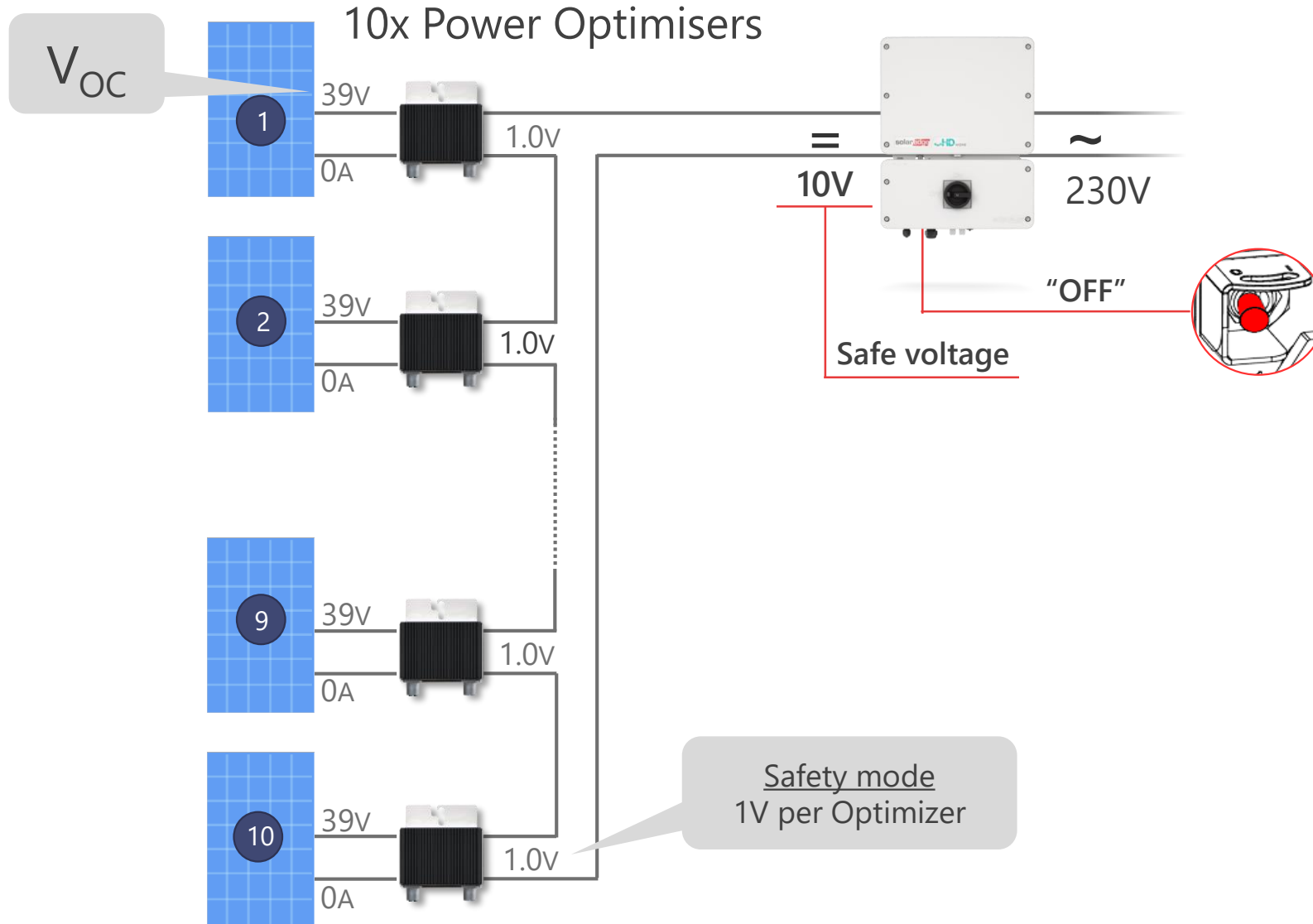

Simple Design Tips

- Power optimisers work best when they are not pushed to their limits
- Longer strings are more capable of dealing with shade than shorter strings
- Higher voltage power optimisers (like P505s) are more capable of dealing with shade than lower voltage power optimisers (like P401s)
- The string current is under the control of the inverter, so the maximum current on the roof will be dictated by the maximum input current of the inverter you are using, regardless of how many strings you parallel

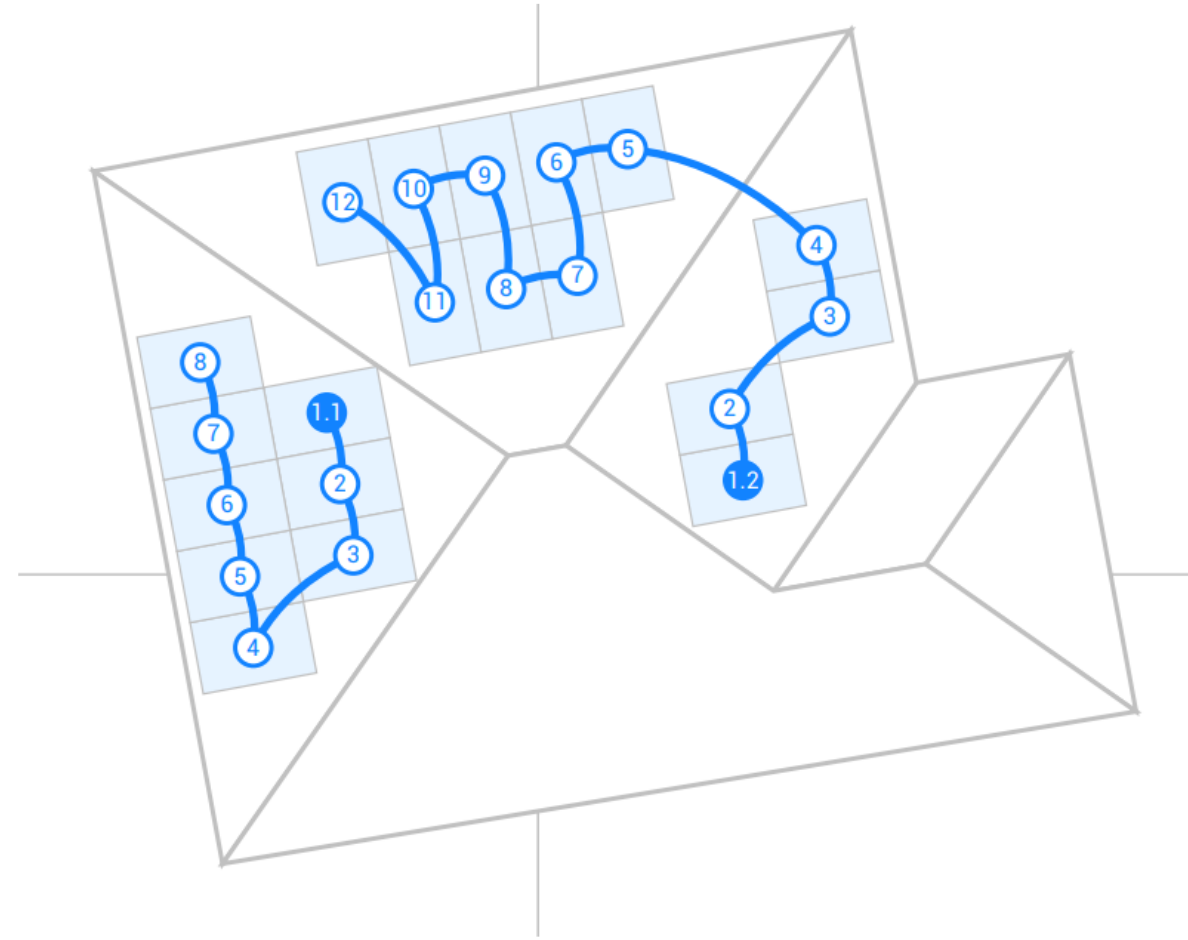

Simple Design Tips

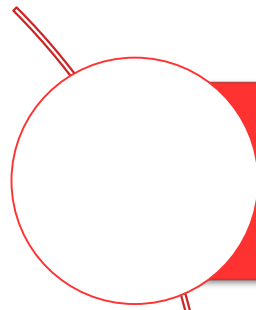
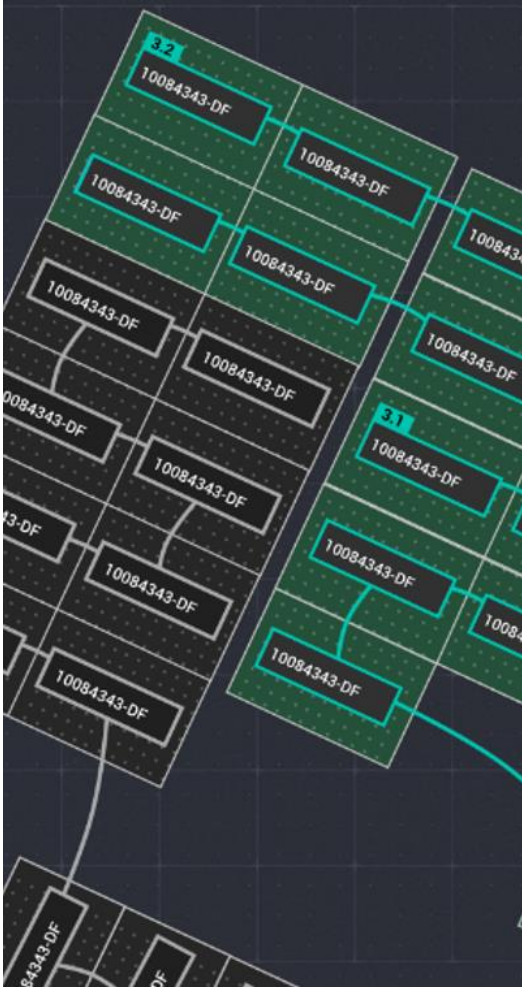

Long strings often minimize balance of system costs, as well as improving system performance

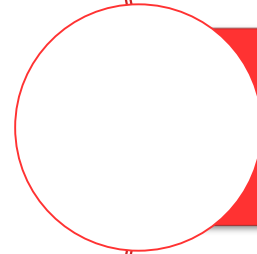

Where possible, **string your system as the sun moves** – if necessary, combine east facing panels with north facing panels and similarly north with west

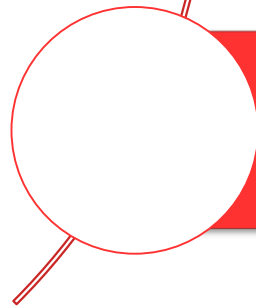

Avoid combining east and west facing panels on the same string - those parts of the roof will operate at different times of day, consequently not helping each other reach the fixed string voltage

For Best Results, Plan Before Going to Site

Free online design validation



- Free 30 min Edge Academy course available on demand (CPD points available)
- Accessed via SolarEdge Account Login
- Set-up a single, individual or Residential & Commercial accounts to manage designs

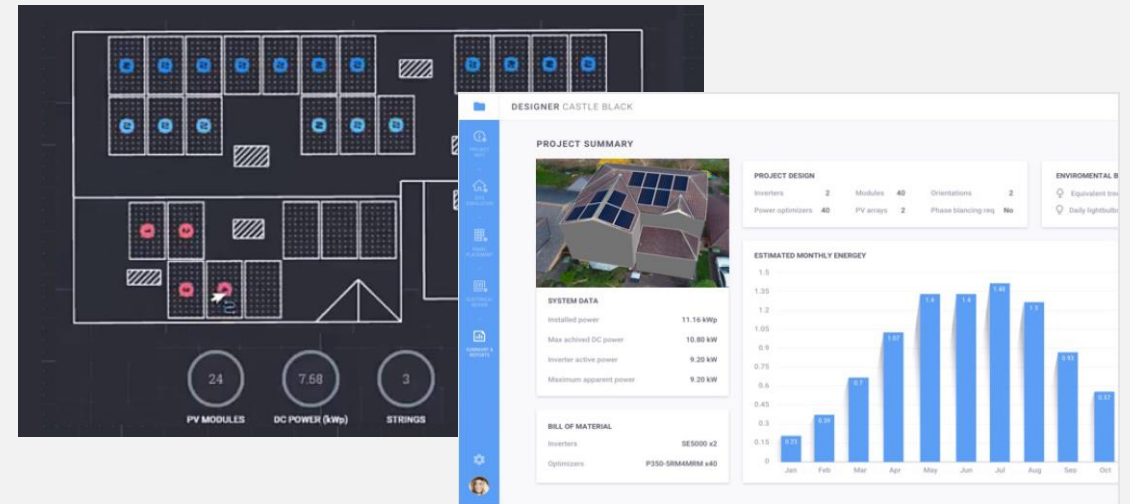

- Design capability for any building type
- Model different designs and energy output
- Incorporates design rules & validates warranties
- Generate design & yield reports for homeowner

Onsite, Key Information Is On Our Datasheets



Our Optimiser and inverter datasheets provide crucial design information on site

In particular check minimum number of optimisers for the string to function and the maximum wattage allowed on the string

You will find the maximum current on the DC side by referring to the maximum input current for your inverter model

PV System Design Using a Solaredge Inverter ⁽⁵⁾		Single Phase HD-WAVE	Single Phase	Three Phase Residential	Three Phase Commercial	
Minimum String Length (Power Optimisers)	P401, P500	8		9	16	
	P505	6		8	14	
Maximum String Length (Power Optimisers)		25		25	50	
Maximum Nominal Power per String		5700 ⁽⁶⁾ (6000 with SE8000H, SE10000H)	5250 ⁽⁶⁾	5625 ⁽⁶⁾	11250 ⁽⁷⁾	W
Parallel Strings of Different Lengths or Orientations		Yes				

(5) It is not allowed to mix P505 with P401/P500 in one string

(7) It is allowed to install up to 13,500W per string when the maximum power difference between each string is 2,000W

(6) If the inverters rated AC power \leq maximum nominal power per string, then the maximum power per string will be able to reach up to the inverters maximum input DC power Refer to: <https://www.solaredge.com/sites/default/files/se-single-string-power-optimizer-application-note-aus.pdf>

Single String Design Examples

Good Design

370w panels, P401 optimisers (max 60VDC)

In the morning, this system has 8 panels in full light, plus significant light on the northern panels. The eastern optimisers would contribute around 40VDC each to the string

If significant shade was a concern, then high output optimisers would be preferred, for extra headroom on the string

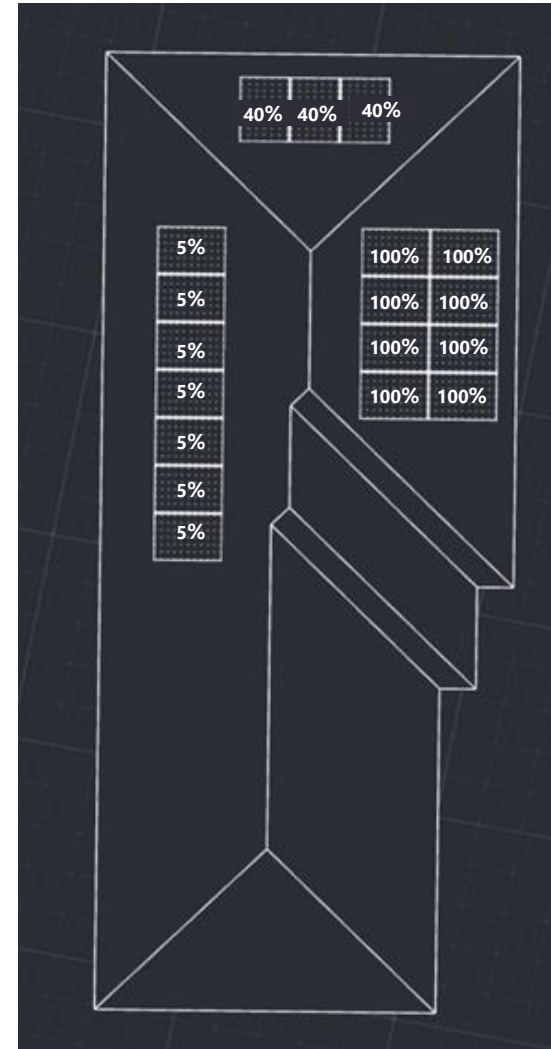
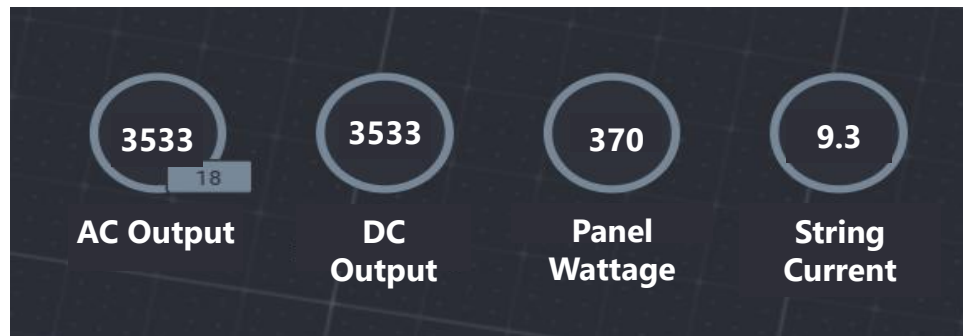

Single String Design Examples

Good Design

370w panels, P401 optimisers (max 60VDC)

This system has 8 facing east and 9 facing west, so all day there will be at least 8 panels in light.

If significant shade was a concern, then high output optimisers would be preferred, for extra headroom on the string

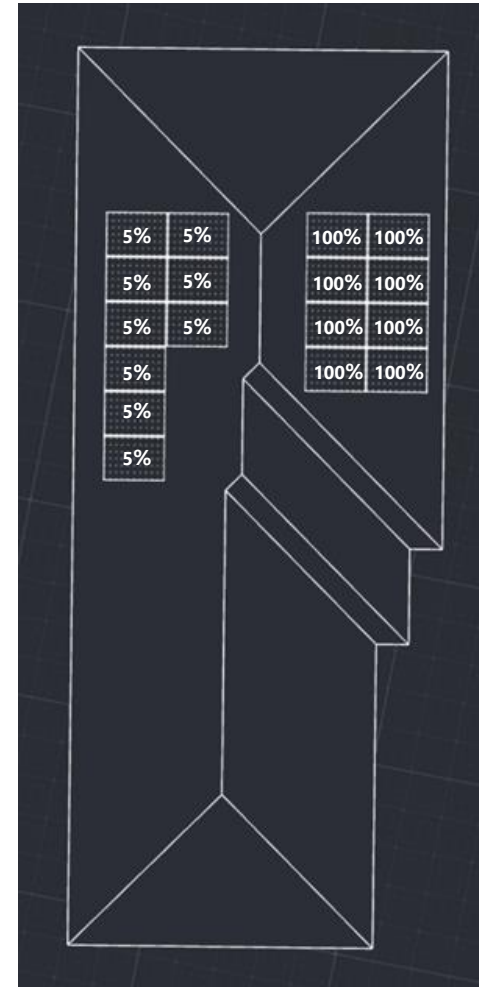
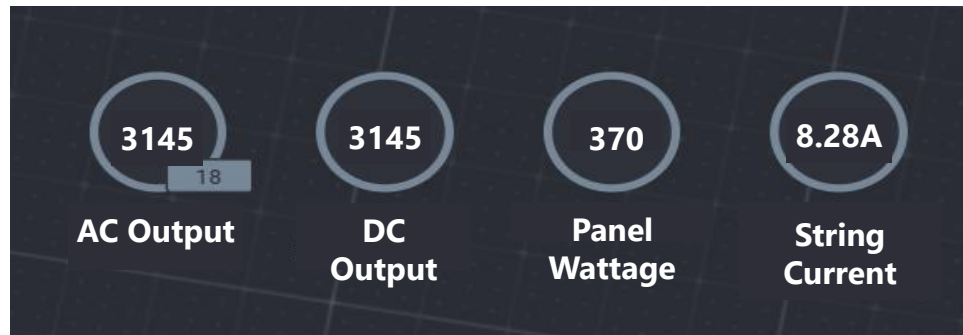

Single String Design Examples

Poor Design

370w panels, P401 optimisers (max 60VDC)

This system has only 4 panels facing east, so in the morning it will perform poorly, as there are less than 8 panels in light. The four optimisers on the eastern panels will all be pushed hard to 60V, their maximum output

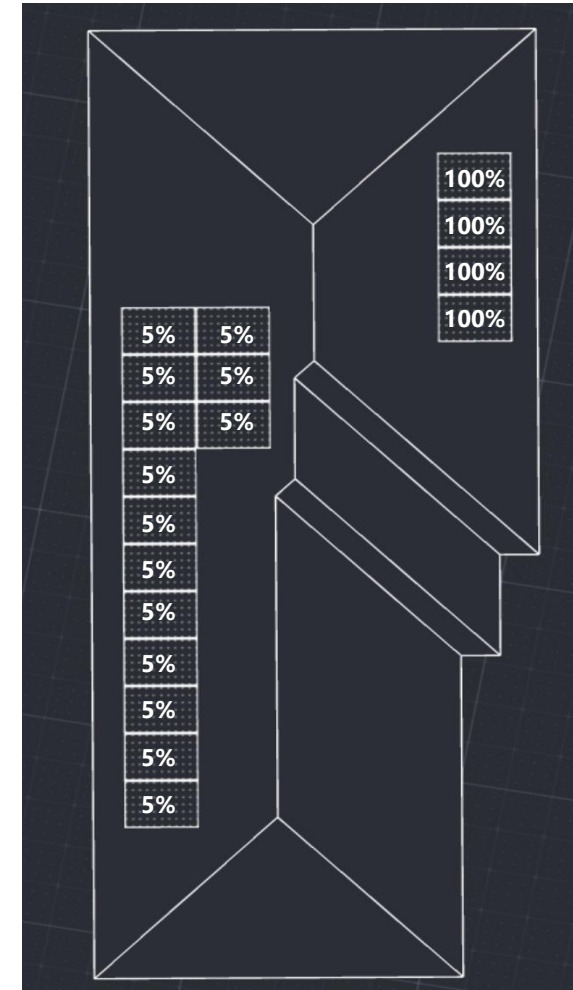
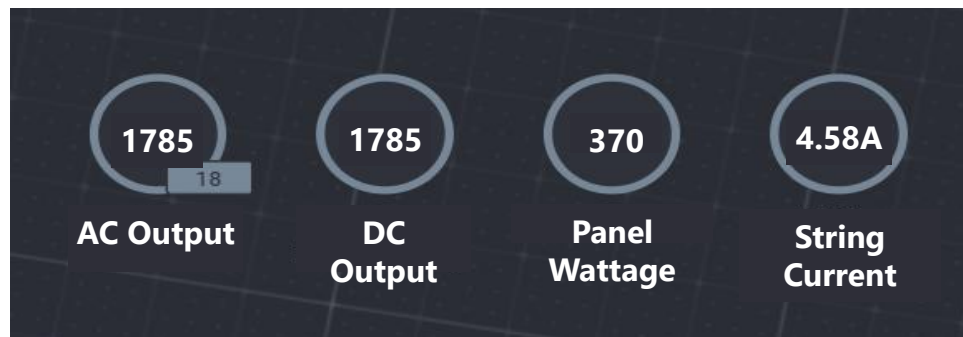

Thank You!

Cautionary Note Regarding Market Data & Industry Forecasts

This power point presentation contains market data and industry forecasts from certain third-party sources. This information is based on industry surveys and the preparer's expertise in the industry and there can be no assurance that any such market data is accurate or that any such industry forecasts will be achieved. Although we have not independently verified the accuracy of such market data and industry forecasts, we believe that the market data is reliable and that the industry forecasts are reasonable.

Version #: 11/2018/NAM

solar**edge**